

# Studies on the Structure of a Lipopolysaccharide from *Mycobacterium* Species

CLINTON E. BALLOU

Department of Biochemistry, University of California, Berkeley, California 94720

Received July 16, 1968

Lipids and carbohydrates form two large classes of natural products which have been studied in great detail in terms of their chemistry, physics, and biology. This attention is clearly warranted because of the important roles these substances play in the physiology of living cells. At the structural interface between lipids and carbohydrates are substances of mixed character which have received much less attention. These substances are classified as *glycolipids* and *lipopolysaccharides*, the distinction being made mainly on the basis of the size of the carbohydrate component. While numerous glycolipids have been characterized<sup>1</sup> (some representative structures are shown in Figure 1), the structures of

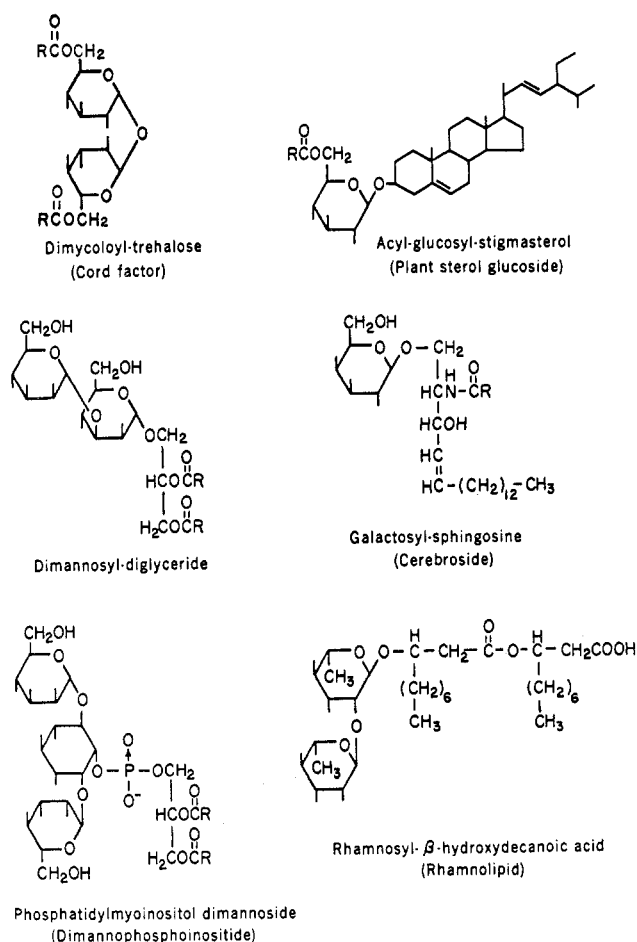

Figure 1. Structures of some representative glycolipids. In several of the examples, the compound shown is a member of a family of compounds which contain additional sugar units and in some cases additional fatty acids.

(1) H. E. Carter, P. Johnson, and E. J. Weber, *Ann. Rev. Biochem.*, **34**, 109 (1965).

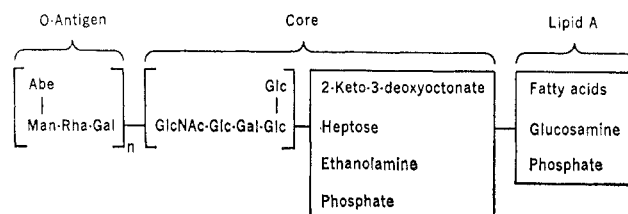

Figure 2. General outline of the structure of the O-antigen lipopolysaccharide from *Salmonella typhimurium*. The abbreviations are: Abe = abequose, Gal = galactose, Glc = glucose, GlcNAc = *N*-acetylglucosamine, Man = mannose, Rha = rhamnose.

the lipopolysaccharides are poorly defined. Perhaps the most extensively investigated of the latter is the cell wall O-antigen lipopolysaccharide of the bacterium *Salmonella typhimurium*,<sup>2</sup> the general structure of which is outlined in Figure 2.

During studies on the glycolipids of *Mycobacterium phlei*,<sup>3</sup> we were attracted to a new kind of lipopolysaccharide in this organism by the fact that the substance contained 6-*O*-methyl-*D*-glucose, a methyl ether not previously reported to occur in nature.<sup>4</sup> Upon purification and characterization of the lipopolysaccharide, other unusual features came to light which will be described in this report. Our present knowledge of the structure of the methylglucose lipopolysaccharide (MGLP) of *M. phlei* is shown in Figure 3 and makes this the most thoroughly characterized representative of this class of natural products.<sup>5-8</sup> As this structure indicates, the work has had two parts—sequencing the polysaccharide and identifying the lipid component. Still unfinished is a determination of the location of the individual lipid components on the polysaccharide.

Sequencing of natural polymers has received considerable attention because of the desire to understand the relation between structure and function of proteins and nucleic acids. The same attention has not been directed to polysaccharides. There are obvious reasons for this. The structures of homopolymers such as starch and cellulose are chemically monotonous, and there is no reason to believe that they or the known

(2) O. Lüderitz, A. M. Staub, and O. Westphal, *Bacteriol. Rev.*, **30**, 192 (1966).

(3) Y. C. Lee and C. E. Ballou, *Biochemistry*, **4**, 1395 (1965).

(4) Y. C. Lee and C. E. Ballou, *J. Biol. Chem.*, **239**, PC3602 (1964).

(5) Y. C. Lee, *ibid.*, **241**, 1899 (1966).

(6) M. H. Saier, Jr., and C. E. Ballou, *ibid.*, **243**, 992 (1968).

(7) J. M. Keller and C. E. Ballou, *ibid.*, **243**, 2905 (1968).

(8) M. H. Saier, Jr., and C. E. Ballou, *ibid.*, **243**, 4319, 4332 (1968).

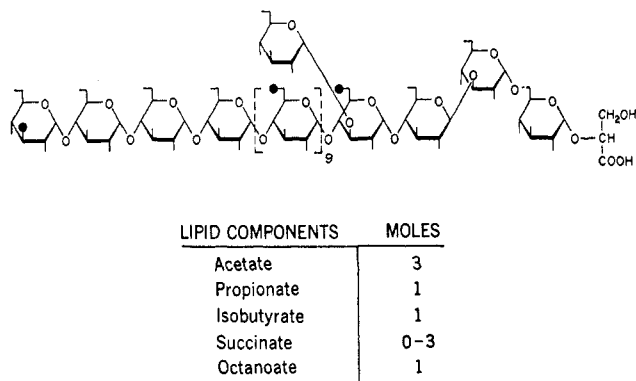

Figure 3. Structure of the polysaccharide component from the methylglucose lipopolysaccharide from *Mycobacterium phlei* and a list of the acyl groups which form the lipid component. The closed circles stand for *O*-methyl groups. All sugars have the *D*-glucose configuration. Although the exact distribution of the acyl groups is unknown, they appear to be esterified mainly to the primary hydroxyl groups of the glucose residues.

heteropolymers, such as heparin or chondroitin sulfate, contain a high level of information. However, a number of polysaccharide materials do carry information of a kind, namely that associated with their antigenic properties. It is in this area of biology that the most careful study has been made of the relation of polysaccharide structure to biological activity, an important example being the structural determinants of the blood group substances.<sup>9</sup> Part of the impetus for the study of the mycobacterial lipopolysaccharides comes from the possibility that these substances might carry biological information of a similar type.

**Isolation of the Lipopolysaccharide.** Isolation of the MGLP<sup>5-7</sup> is facilitated by its unique size (mol wt ~3500), its solubility, and its acidic property. It may be extracted from the bacterial cell, along with other lipids, by 70% ethanol, and it is separated from the nonpolar lipids by distribution between chloroform and water. Filtration of the water-soluble fraction through Sephadex G-50 resolves the lipopolysaccharide from impurities of larger and smaller size. Finally the MGLP may be resolved into four fractions by gradient salt elution from a column of DEAE-Sephadex (Figure 4). Each MGLP fraction has been shown to yield the

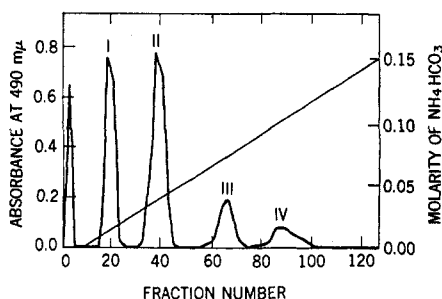

Figure 4. Elution pattern of the lipopolysaccharide mixture from diethylaminoethyl-Sephadex (DEAE-Sephadex). Absorbance at 490  $m\mu$  represents carbohydrate determined by the phenol-sulfuric acid procedure.

Table I  
Properties of the Polysaccharide Component

Molecular weight	3060 $\pm$ 3%
Equivalent weight	3080
pK of acid dissociation	3.5
Mol of methylglucose/mol of glucose	1.5
Optical rotation	$[\alpha]_D +160^\circ$ (water) <sup>a</sup>
Methylation products	2,3,4,6-Tetra- <i>O</i> -methylglucose (1 mol) 2,3,6-Tri- <i>O</i> -methylglucose (7-9 mol) 2,6-Di- <i>O</i> -methylglucose 3- <i>O</i> -Methylglyceric acid

<sup>a</sup> Amyloheptaose has  $[\alpha]_D +179^\circ$  (water). The molecular rotation per hexose unit is  $+2960^\circ$  for amyloheptaose and  $+2820^\circ$  for the polysaccharide, assuming 18 hexose units/mol and an acidic component with mol wt ~100.

same polysaccharide component after saponification. The DEAE-Sephadex fractions differ from each other on the basis of anionic charge, a difference which is correlated with the content of succinic acid.

**General Structure of the Polysaccharide.** Polysaccharide (MGP) obtained by saponification of MGLP has the properties listed in Table I.<sup>4,5</sup> The presence of a methyl ether was first suspected from the resonance line at 3.3 ppm in the nmr spectrum (Figure 5B) and was established by the isolation of 6-*O*-methyl-*D*-glucose after acid hydrolysis of MGP. The equivalent weight obtained by titration and the molecular weight determined by sedimentation equilibrium both corre-

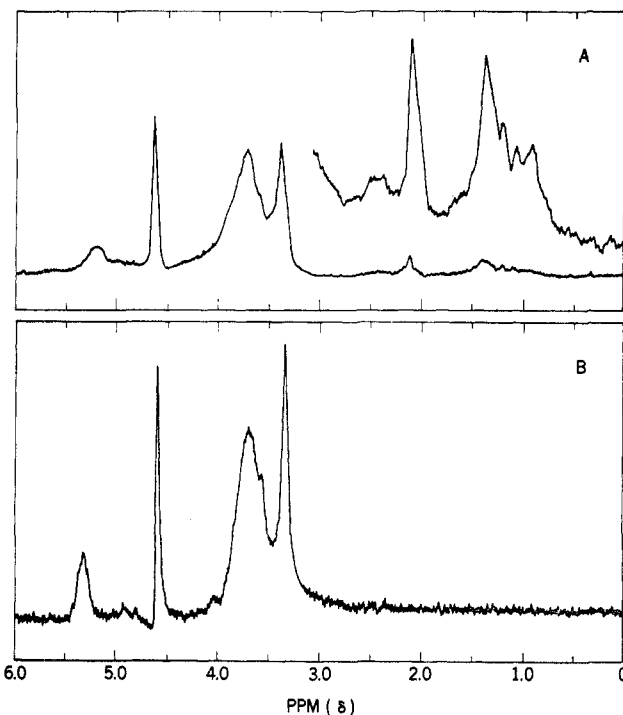

Figure 5. Nuclear magnetic resonance spectra (Varian A-60) of the lipopolysaccharide (A) and the polysaccharide (B) in deuterium oxide. The line at 4.6 ppm is HDO, the anomeric protons of the sugars are at 5.4 ppm, the ring protons of the sugars at about 3.7 ppm, the *O*-methyl groups at 3.3 ppm, and the acyl groups in the region 1-2.5 ppm.

(9) W. M. Watkins, *Science*, 152, 172 (1966).

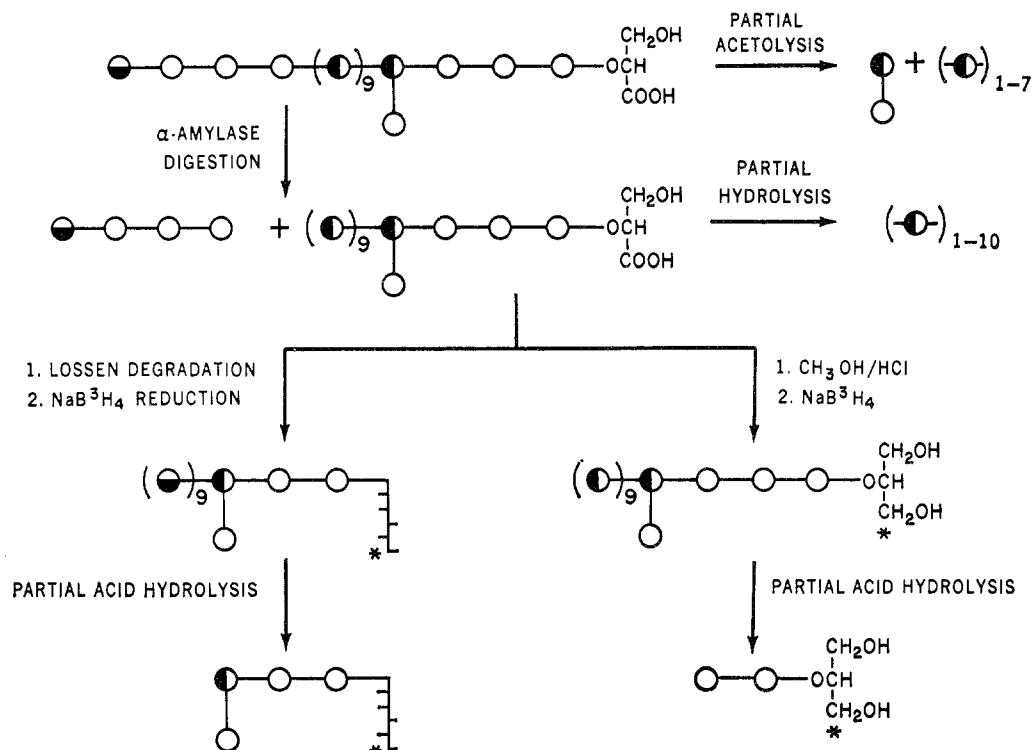
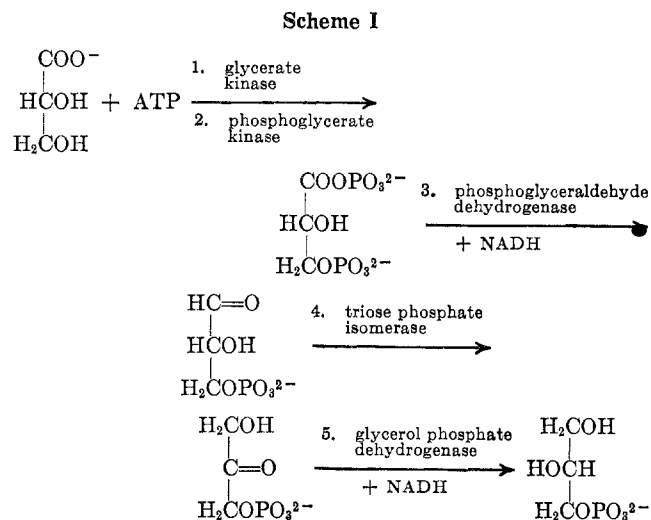

Figure 6. Outline of the procedures used for the selective degradation of the polysaccharide: O, glucose; ●, 3-*O*-methylglucose; and ○, 6-*O*-methylglucose. The star represents the position of labeling with tritium.

spond to a molecule of 18 hexose units. The ratio of glucose to methylglucose was about 2:3, which agrees with the ratio of 7:11 derived for the assigned structure in Figure 3. That the polysaccharide has a single branch is clear from the ratio of tetra-*O*-methylglucose obtained from permethylated MGP (Table I). Since the tri-*O*-methylglucose was mainly the 2,3,6 isomer, 1→4 linkages must predominate. The optical rotation and the nmr spectrum (Figure 5B) suggest that they have the  $\alpha$  configuration. These features led us, during the early stages of the investigation, to suspect that the polysaccharide might be related to amylose or glycogen, both of which are homopolymers of *D*-glucose connected mainly by  $\alpha$ (1→4) linkages. However, as the final structure indicates, such a relationship probably does not exist.

The polysaccharide is nonreducing, and we concluded that it must be linked to a nonreducing aglycon which probably also carried the acidic function, presumably a carboxyl group. Two possibilities seemed likely: a ketodeoxyoctonic acid or a  $\beta$ -hydroxy fatty acid, both of which are found in the *Salmonella* lipopolysaccharide. These two were readily eliminated, and the question was eventually resolved by the isolation of glyceric acid from the acid hydrolysate of MGP.<sup>6</sup> Since 3-*O*-methylglyceric acid was obtained from methylated MGP, the glycosidic linkage must involve position 2 of the acid. This appears to be the first report of the presence of glyceric acid in a polysaccharide, although it has been found as the aglycon in a glycoside from the alga *Polyriphoria fustigiata*.<sup>10</sup> The configuration of the



glyceric acid was established from its reaction in an enzyme-coupled assay.<sup>11</sup> This assay is carried out with a rabbit muscle extract and involves the enzyme-catalyzed steps shown in Scheme I. The oxidation of reduced nicotinamide-adenine dinucleotide (NADH) is followed spectrophotometrically and is dependent upon and proportional to the *D*-glyceric acid content. *L*-Glyceric acid is not attacked.

**Determination of Polysaccharide Sequence.** This aspect of the problem was divided into three parts: sequencing the nonreducing end terminated by the 3-*O*-methylglucose, the reducing end attached to the glyceric acid, and the middle section which contained

(10) H. Colin and J. Augier, *Compt. Rend.*, **208**, 1450 (1939).

(11) A. R. Archibald, J. Baddiley, and J. G. Buchanan, *Biochem. J.*, **81**, 124 (1961).

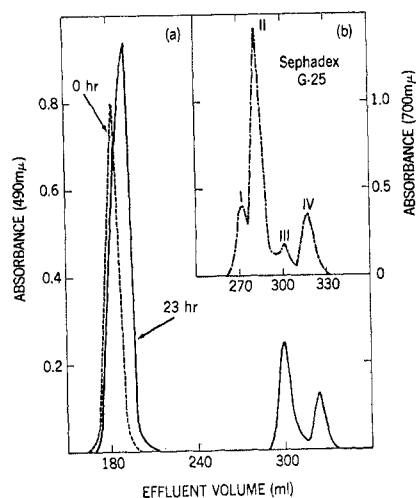

Figure 7. Gel filtration of the products from the action of  $\alpha$ -amylase on the polysaccharide. Peaks I, II, III, and IV in the inset identify tetrasaccharide, trisaccharide, disaccharide, and monosaccharide, respectively. Absorbance at 700  $m\mu$  represents reducing power. Figure 7a is the product of exhaustive digestion while 7b is for a limited (9 hr) digestion.

the 6-*O*-methylglucose. The general scheme is outlined in Figure 6.<sup>8</sup>

**Sequence at the Nonreducing End.** The presence of  $\alpha(1\rightarrow4)$  linkages in the polysaccharide suggested the possibility that amylases, enzymes which normally act to hydrolyze the  $\alpha(1\rightarrow4)$  linkages in starch, might attack the molecule and lead to a selective degradation. This proved to be so. Short-term digestion of MGP with porcine pancreas  $\alpha$ -amylase (Figure 7) yielded initially a tetra- and a trisaccharide (inset b), each of which was degraded by further digestion to a disaccharide and *D*-glucose. The disaccharide had *D*-glucose at its reducing end and 3-*O*-methyl-*D*-glucose at the nonreducing end, the two being connected by an  $\alpha(1\rightarrow4)$  linkage. Both larger fragments had 3-*O*-methyl-*D*-glucose at the nonreducing end. The homologous relationship between these fragments is reflected in their chromatographic properties (Figure 8).

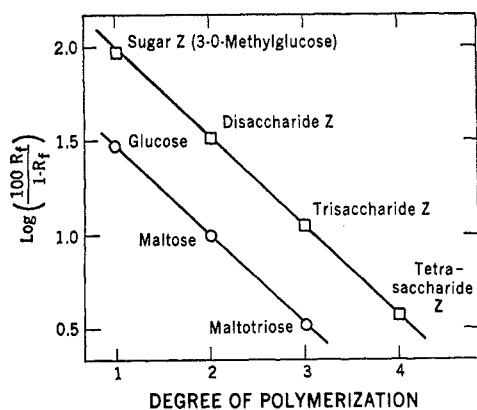

Figure 8. A plot of the log of the rate of migration on paper chromatography against the degree of polymerization of the oligosaccharides, containing 3-*O*-methylglucose, obtained by amylase digestion of the polysaccharide. These oligosaccharides are identified with the letter Z.

The plot of a log function of the rates of migration against the degree of polymerization gives a straight line, as expected.<sup>12</sup> That this line is parallel to a similar plot of the amylooligosaccharides is evidence that the substances differ only by the single 3-*O*-methylglucose unit at the nonreducing end. From these experiments we conclude that one of the two nonreducing ends of MGP was terminated by the tetrasaccharide depicted in Figure 9.

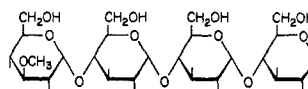

Figure 9. Structure of tetrasaccharide Z, the largest fragment containing 3-*O*-methylglucose released from the polysaccharide by the action of  $\alpha$ -amylase.

The discovery of 3-*O*-methylglucose at one end of the polysaccharide was a surprise, although this sugar has also been found as a component of a sterol glycoside in the poisonous principle of the sea-cucumber (*Actinopyga agassizi*).<sup>13</sup> Initial studies on the methylation of MGP had yielded 2,3,4,6-tetra-*O*-methylglucose from the two nonreducing end groups (Table I), and the presence of 3-*O*-methylglucose was hidden by this reaction. The methylation technique for investigating polysaccharide structure has an obvious limitation when one is dealing with a polysaccharide that already contains some methyl groups. In this case, the limitation was circumvented by carrying out the alkylation with propyl iodide. MGP treated in this way yielded equal parts of 2,3,4,6-tetra-*O*-propylglucose and 3-*O*-methyl-2,4,6-tri-*O*-propylglucose, thus giving direct evidence for the nature of the two end groups. Propylation of the large fragment, obtained by exhaustive digestion of MGP with  $\alpha$ -amylase and glucoamylase, gave 2,3,4,6-tetra-*O*-propylglucose and 6-*O*-methyl-2,3,4-tri-*O*-propylglucose as the two end groups. Thus, it is apparent that the enzymic digestion removed the tetrasaccharide fragment containing 3-*O*-methylglucose and simultaneously exposed a new end terminated by 6-*O*-methylglucose.<sup>5</sup>

**The Sequence at the Reducing End of the Polysaccharide.** The nature of the sugar units, at what would otherwise be the reducing end of MGP, was investigated following the removal of the glyceric acid moiety. This selective degradation was accomplished under very mild conditions *via* a Lossen rearrangement effected by a carbodiimide reagent according to Hoare, Olson, and Koshland.<sup>14</sup> The reaction is outlined in Figure 10. As a dividend, this reaction confirmed that the linkage of the first sugar unit was to position 2 of the glyceric acid. Had it been to position 3, the glyceric acid would have been degraded to glycolaldehyde without rupture of the glycosidic linkage. This deg-

(12) D. French and G. M. Wild, *J. Am. Chem. Soc.*, **75**, 2612 (1953).

(13) J. D. Chanley, R. Ledeen, J. Wax, R. F. Nigrelli, and H. Sobotka, *ibid.*, **81**, 5180 (1959).

(14) D. G. Hoare, A. Olson, and D. E. Koshland, Jr., *ibid.*, **90**, 1638 (1968).

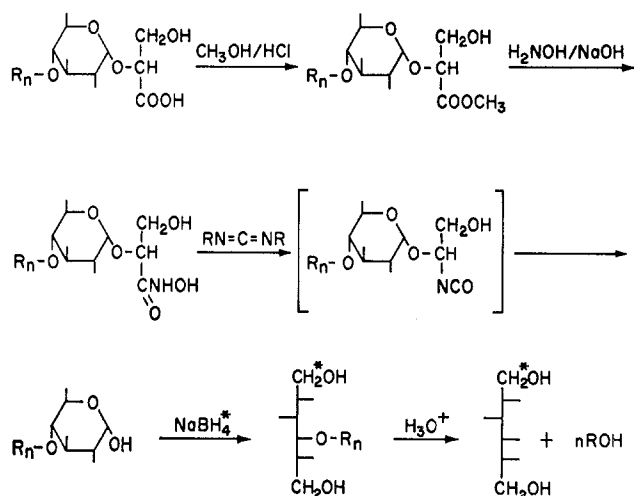

Figure 10. The sequence for the selective removal of glyceric acid from the polysaccharide.  $R_n$  stands for the rest of the molecule and the star indicates the position that became labeled with tritium after reduction with sodium borotritide.

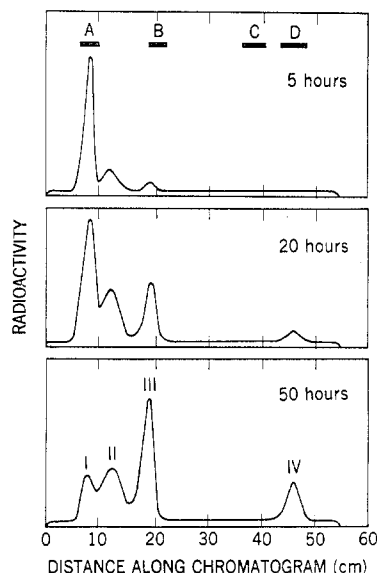

Figure 11. Representation of the radioactive fragments obtained by partial acid hydrolysis of the polysaccharide after removal of the glyceric acid and reduction with sodium borotritide. The bars at the top of the figure represent the areas on the chromatograms occupied by starting material (A), maltitol (B), 6-*O*-methylglucosylglucitol (C), and glucitol (D). In the bottom figure, peak III was identified as isomaltitol and peak IV as glucitol. Peak II gave, on resolution by paper chromatography, a tri-, a tetra-, and a pentasaccharide, the structures of which are illustrated in Figure 12.

radiative procedure holds considerable promise in carbohydrate chemistry, one possibility being for the selective cleavage of polymers which contain uronic acid.<sup>15</sup>

The hexose, newly exposed by removal of the glyceric acid, was labeled by reduction with sodium borotritide so that the radioactive product obtained by complete acid hydrolysis could be identified. Since this labeled product, peak IV in Figure 11, was glucitol, it is ap-

parent that glucose was the sugar directly attached to the glyceric acid. Partial acid hydrolysis of the same labeled MGP fragment yielded a series of oligosaccharides containing the tritiated glucitol moiety, varying in size from a di- to a pentasaccharide (Figure 11). The disaccharide (peak III, Figure 11) was identical with isomaltitol. The trisaccharide was hydrolyzed by  $\beta$ -glucosidase (emulsin) to glucose and isomaltitol-<sup>3</sup>H. Periodate oxidation of the trisaccharide left one of the two glucose units intact, indicating that the one at the nonreducing end was attached by a 1 $\rightarrow$ 3 linkage. The tetrasaccharide fragment contained a single 6-*O*-methylglucose unit attached by an  $\alpha$ (1 $\rightarrow$ 4) linkage, in addition to those components of the trisaccharide. Finally, the pentasaccharide was made up from the tetrasaccharide which was substituted by a *D*-glucose unit in such a way that it protected the 6-*O*-methylglucose from oxidation by periodate and could be removed by the action of an  $\alpha$ -glucosidase (obtained from the yeast *Debaryomyces vanryyi*). These facts imply an  $\alpha$ (1 $\rightarrow$ 3) linkage. The structures of the oligosaccharides<sup>6</sup> are illustrated in Figure 12.

**Configuration of the Glucosidic Linkage to Glyceric Acid.** Attempts to isolate glucosylglycerate following partial hydrolysis or acetolysis of the polysaccharide were not successful. However, the following procedure, outlined in Figure 6, allowed the determination of the anomeric configuration between the glucose and the glyceric acid. MGP was converted to the methyl ester which was reduced with sodium borotritide so that the methyl glycerate was converted to tritium-labeled glycerol. By a controlled acid hydrolysis of this material fragments were isolated which corresponded to glucosylglycerol and isomaltosylglycerol. The former was subjected to the action of both  $\alpha$ - and  $\beta$ -glucosidases. Only the  $\alpha$ -glucosidase was effective in releasing radioactive glycerol from the glucoside.

**The 6-*O*-Methylglucose-Containing Section of the Polysaccharide.** The location of three *D*-glucose units at the nonreducing end of the polysaccharide terminated by 3-*O*-methylglucose, a single *D*-glucose unit at the other nonreducing end, and three *D*-glucose units at the "reducing end" attached to the *D*-glyceric acid accounts for all of the *D*-glucose in the molecule. This suggests that the ten molecules of 6-*O*-methyl-*D*-glucose form a unit in the middle of the polymer. Evidence for this was obtained in two ways. First, controlled acetolysis of MGP yielded fragments up to the heptasaccharide in length which were composed entirely of 6-*O*-methyl-*D*-glucose.<sup>5</sup> In a second experiment, MGP was digested with  $\alpha$ -amylase and glucoamylase to remove the 3-*O*-methylglucose-containing tetrasaccharide unit. The amylase-resistant core was then subjected to partial acid hydrolysis and the fragments were labeled by reduction with sodium borotritide. By a combination of gel filtration and paper chromatography the fragments containing tritiated 6-*O*-methylglucitol and 6-*O*-methylglucose, but no glucose, were isolated. The largest was a decasaccharide (Figure 13). The plot of chromatographic property as a function of degree of

(15) N. K. Kochetkov, O. S. Chizhov, and A. F. Sviridov, *Carbohydr. Res.*, **4**, 362 (1967).

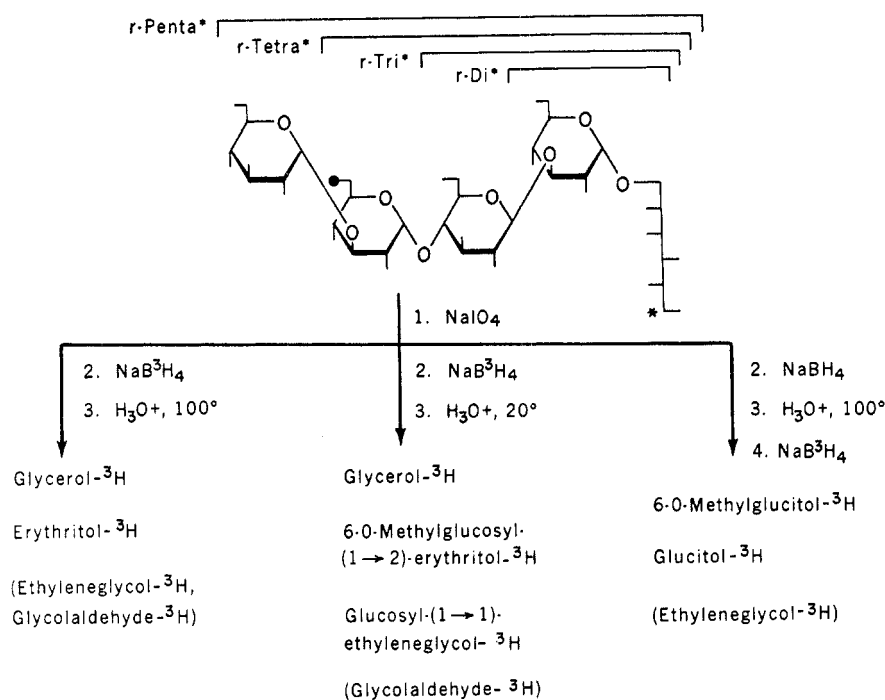

Figure 12. Illustration of the structures of the labeled products obtained by the partial acid hydrolysis outlined in Figure 11. The substances in parentheses were not identified.

polymerization in Figure 13 gives a linear relationship, as expected for an homologous series.

**The Branch Point of the Polysaccharide.** The methylation studies had established that the polysaccharide had two end groups and the propylation study that one of them was 3-*O*-methylglucose while the other was glucose. The 3-*O*-methylglucose was shown to be a part of the tetrasaccharide unit which was attached to the end of the chain of 6-*O*-methylglucose units. Early studies on the acetolysis of MGP had yielded the disaccharide *O*- $\alpha$ -D-glucopyranosyl-(1 $\rightarrow$ 3)-6-*O*-methyl-D-glucose<sup>5</sup> which we believe represents the branch point, the glucose unit being the other end group found by methylation. This conclusion is confirmed by the fragments obtained by partial acid hydrolysis of the polysaccharide which show in the pentasaccharide (Figure 12) a single glucose in  $\alpha$ (1 $\rightarrow$ 3) linkage to a 6-*O*-methylglucose unit. We also believe that this 6-*O*-methylglucose heads the reducing end of the chain of ten 6-*O*-methylglucose units which were detected by partial acid hydrolysis.

**Periodate Oxidation of MGP.** The structure in Figure 3 was confirmed in most respects by periodate oxidation. Such studies may be done on a microscale by using the spectrophotometric procedure to follow periodate consumption<sup>16</sup> and the enzymic method of Rammler and Rabinowitz for determination of formate.<sup>17</sup> The consumption of oxidant was 16.5–17.5 mol/mol of MGP, the calculated value being 17. One mole each of glucose, 3-*O*-methylglucose, and 6-*O*-methylglucose survived the oxidation (Figure 14), consistent with substitution on the 3 position of each of these units.

Reduction of the periodate-oxidized polymer with sodium borotritide labeled the oxidized fragments, which were then identified and estimated following acid hydrolysis. All 6-*O*-methylglucose, except for the single unit that is protected at the branch point, was converted to 1-*O*-methylerythritol, a result consistent with the 1 $\rightarrow$ 4 linkages. The ratio of erythritol, from 1 $\rightarrow$ 4-linked glucose units, to 1-*O*-methylerythritol was 4:8.9, while the structure in Figure 3 predicts a ratio of 4:9.

The acyclic acetal linkages, in the product obtained by borohydride reduction of periodate-oxidized polysaccharides, are more sensitive to acid hydrolysis than the remaining glycosidic linkages.<sup>18</sup> Thus, by a controlled acid hydrolysis (0.25 *N* HCl at 25° for 30 hr) it is possible to obtain fragments in which nonoxidized sugar residues are linked glycosidically to adjacent oxidized fragments. When this reaction was applied to amylase-digested MGP, 6-*O*-methylglucopyranosyl-(1 $\rightarrow$ 2)-erythritol and  $\alpha$ -D-glucopyranosyl-(1 $\rightarrow$ 1)-glycerol were obtained as predicted.

**The Lipid Components of MGLP.** Glycolipids and lipopolysaccharides usually contain long-chain fatty acids (10–20 carbons in length) as their lipid component, although acetate is a common constituent. Lipid A of *Escherichia coli* lipopolysaccharide is reported to contain acetate,  $\beta$ -hydroxydecanoate, dodecanoate, tetradecanoate, and  $\beta$ -hydroxytetradecanoate.<sup>19</sup> We expected that the mycobacterial lipopolysaccharide might also contain a long-chain hydroxy fatty acid. In fact, initial attempts failed to identify any fatty acid methyl ester by gas chromatography following methanolysis of

(16) J. S. Dixon and D. Lipkin, *Anal. Chem.*, **26**, 1092 (1954).

(17) D. H. Rammler and J. C. Rabinowitz, *Anal. Biochem.*, **4**, 116 (1962).

(18) H. O. Bouveng and B. Lindberg, *Advan. Carbohydr. Chem.*, **15**, 87 (1960).

(19) A. J. Burton and H. E. Carter, *Biochemistry*, **3**, 411 (1964).

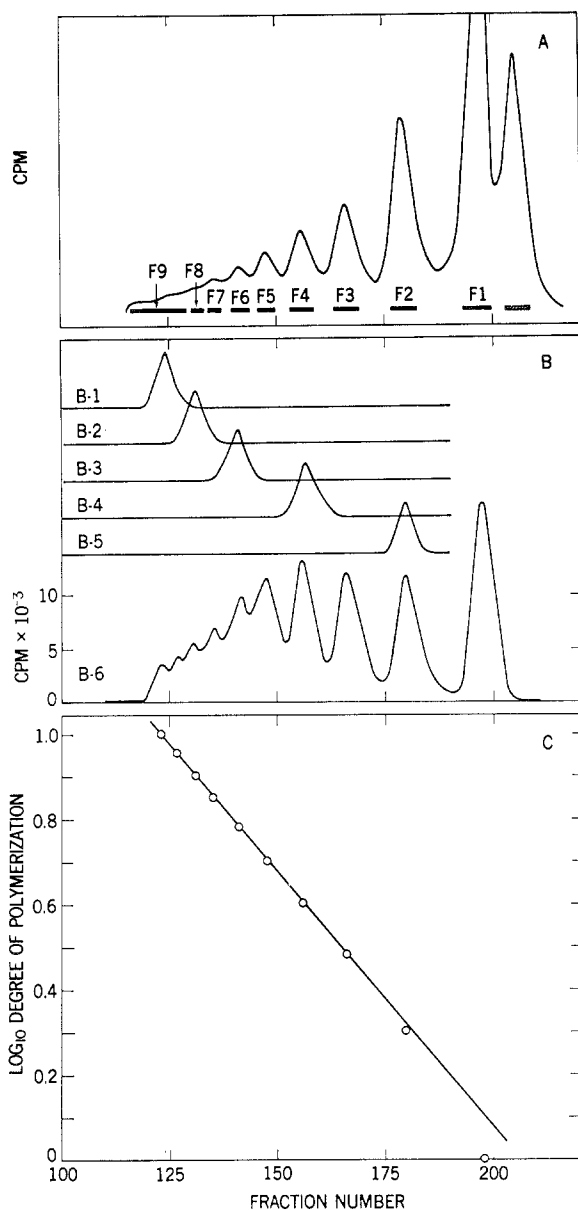

Figure 13. (A) Gel filtration of the labeled products obtained by partial acid hydrolysis and sodium borotritide reduction of amylase digested polysaccharide. These were separated into fractions indicated by the bars and purified by paper chromatography until free of glucose-containing fragments. (B) Gel filtration of some of the purified fractions; (B-6) gel filtration of a synthetic mixture of all of the components. (C) Log plot of the degree of polymerization against the retention volumes of the oligosaccharides.

the lipopolysaccharide.<sup>5</sup> The nmr spectrum of intact MGLP (Figure 5A) suggests the reason. This pattern is characteristic of a mixture of short-chain acyl groups, and because of the volatility of their methyl esters they were apparently lost during processing of the methanolysis reaction. The nature of the lipid component was readily revealed by paper chromatography of the non-volatile acyl hydroxamates obtained by treatment of MGLP with basic hydroxylamine. Products were obtained corresponding to acetyl, propionyl, isobutyryl, octanoyl, and succinyl hydroxamates. The absence of *n*-butyrate, hexanoate, and decanoate was established by gas chromatography.

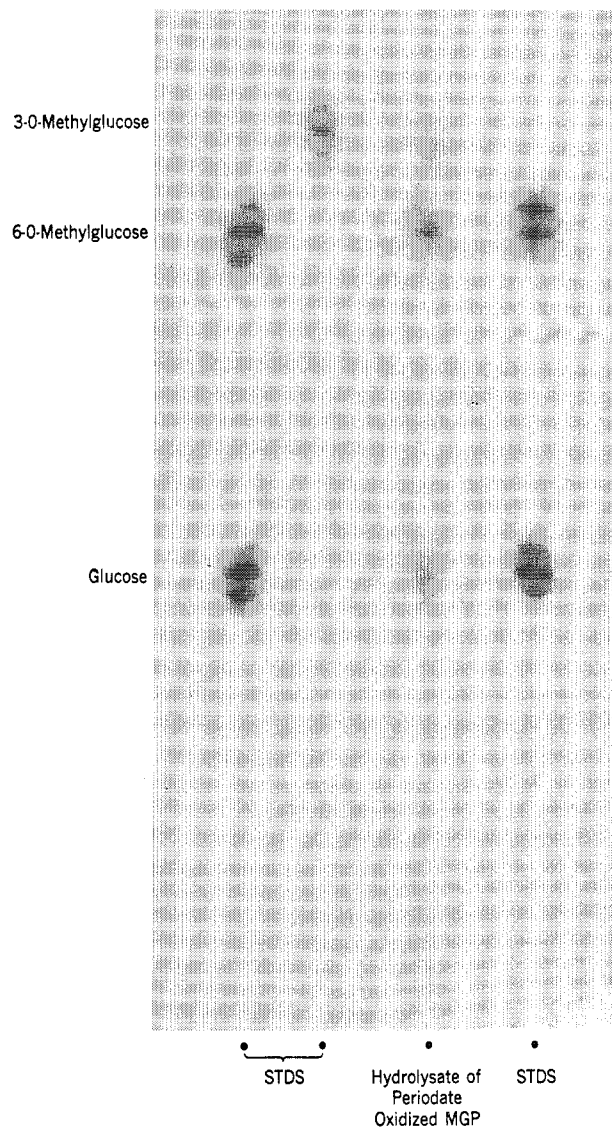

Figure 14. A chromatogram of the hexoses which survive exhaustive oxidation of the polysaccharide by sodium metaperiodate.

The resolution of MGLP into four components by ion-exchange chromatography on DEAE-Sephadex (Figure 4) indicated that there were forms of the molecule with different charge. The identification of *N*-hydroxysuccinamic acid as one of the products of the reaction with hydroxylamine suggested that the additional negative charge arose from variable amounts of monoesterified succinate. Table II confirms this

Table II  
Titer and Ester Content of MGP and MGLP Fractions<sup>a</sup>

Fraction	Base consumed on titration	Total ester content	Succinic acid content
MGP	1.0	0	0
MGLP-I	0.95	5.4	0
MGLP-II	1.75	6.8	0.94
MGLP-III	2.75	8.0	1.86

<sup>a</sup> The values are given as mol/mol of polysaccharide, assuming 18 hexose units/mol.

conclusion and shows that, while MGP and MGLP-I have a single titratable acid group owing to the glyceric acid moiety, MGLP-II and III have, respectively, one and two additional acid dissociations which are correlated with the amount of succinic acid in each. MGLP-IV appears to contain 3 mol of succinic acid.

While the discovery of acetate in the mycobacterial lipopolysaccharide is not surprising, the over-all assortment of acyl groups in the molecule is unprecedented. Monoesterified succinate has been identified as a constituent of the teichoic acid (polyribitolphosphate) of *Actinomyces violaceus*<sup>20</sup> and in a polysaccharide produced by a soil bacterium of the genus *Alcaligenes*,<sup>21</sup> but there does not appear to be any report of the occurrence of propionate, isobutyrate, or octanoate as substituents of any other natural polysaccharide.

The exact location of the acyl groups in the lipopolysaccharide has not been determined, although it is obvious that they must be esterified to the available hydroxyl groups on the sugar residues. A preliminary study of the periodate oxidation of MGLP-I shows that it consumes about the same amount of oxidant as does MGP.<sup>22</sup> This suggests that the acyl groups are on hydroxyls which are not part of any *vic*-glycol grouping. There are seven primary hydroxyl groups on the sugar residues and an eighth on the glyceric acid unit in the polysaccharide. These could be the major points of esterification. However, there are also five secondary hydroxyl groups in MGP on those three hexose units which are protected against periodate oxidation. Thus, a total of 13 positions are available for the six acyl groups which probably exist in MGLP-I.

Two pertinent questions concern whether there is heterogeneity in the distribution of the acyl groups (other than succinic acid) between different molecules and whether there is a specific or random distribution of acyl groups along the polysaccharide chain within a

particular molecular species. The only evidence on the first point is that the nmr spectra of MGLP-I, -II, and -III are quantitatively very similar, which suggests that the lipids have the same average acyl composition. Since the amounts of the acyl groups approach integral values, we are inclined to believe that there is no appreciable heterogeneity in acyl composition.

In favor of a nonrandom distribution of particular acyl groups along the polysaccharide, one experiment can be cited. The enzyme  $\alpha$ -amylase, which is able to cleave the tetrasaccharide unit terminated by 3-*O*-methylglucose from the nonreducing end of the polysaccharide, is also able to cleave corresponding di- and trisaccharide fragments from the end of about 40% of the molecules of MGLP-II. These fragments contain, in ester form, about 1 mol of isobutyrate and acetate per mol of 3-*O*-methylglucose.<sup>22</sup> Thus, it appears that most of the isobutyrate and one-third of the acetate are located on the three sugar residues at this nonreducing terminus of the polysaccharide.

**Biological Function.** The functions of glycolipids and lipopolysaccharides are not well understood. However, many are located on the cell surface and thus are effective antigens. This property may be related to the more general phenomenon of "cell recognition."<sup>23</sup> We have considered these facts in studying the role of the methylglucose lipopolysaccharide. Interestingly, it does not appear to be attached to or to be associated with any cellular organelle. During the growth of the organism, methylglucose lipopolysaccharide is continuously excreted into the medium. Whether this is an active process or whether it merely reflects the lysis of cells we do not know.

*I am pleased to acknowledge the fact that nearly all of the work described in this report was carried out by my coworkers Drs. Y. C. Lee, M. H. Saier, Jr., and J. M. Keller. Together, I believe they have made a unique contribution to the field of lipopolysaccharide structure. These studies have been generously supported by the National Institutes of Health and the National Science Foundation.*

(20) I. B. Naumova, A. Z. Shabarova, and A. N. Belozersky, *Dokl. Akad. Nauk SSSR*, **152**, 1471 (1963).

(21) T. Harada and T. Yoshimura, *Biochim. Biophys. Acta*, **83**, 374 (1964).

(22) J. M. Keller and C. E. Ballou, unpublished experiments.

(23) "The Specificity of Cell Surfaces," B. D. Davis and L. Warren, Ed., Prentice-Hall, Inc., Englewood Cliffs, N. J., 1967.